

Acclaim III

Recessed LED Luminaires

ATEX and IECEx

INSTALLATION, OPERATION AND MAINTENANCE INSTRUCTIONS

Important: Please read these instructions carefully before installing or maintaining this equipment. Good electrical practices should be followed at all times and this data should be used as a guide only.



STANDARD - M300 CEILING

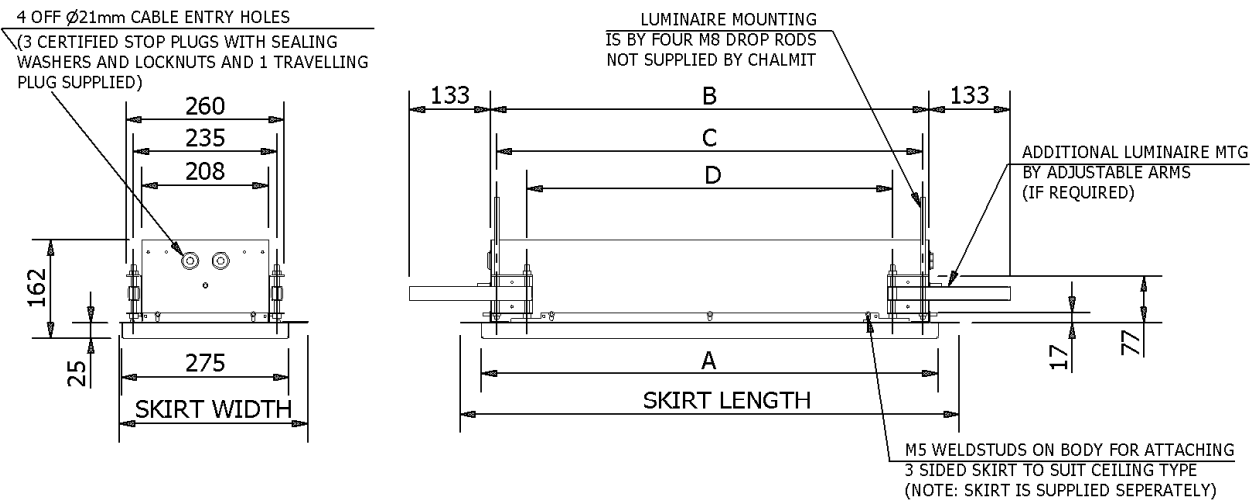

MODEL	A	B	C	D	SKIRT LENGTH	SKIRT WIDTH	CUT OUT SIZES
2X18W	750	720	700	600	820	309	800(L) X M300 TILE WIDTH
2X36W	1365	1335	1315	1215	1435	309	1415(L) X M300 TILE WIDTH

/PC SOLID PLANK CEILING

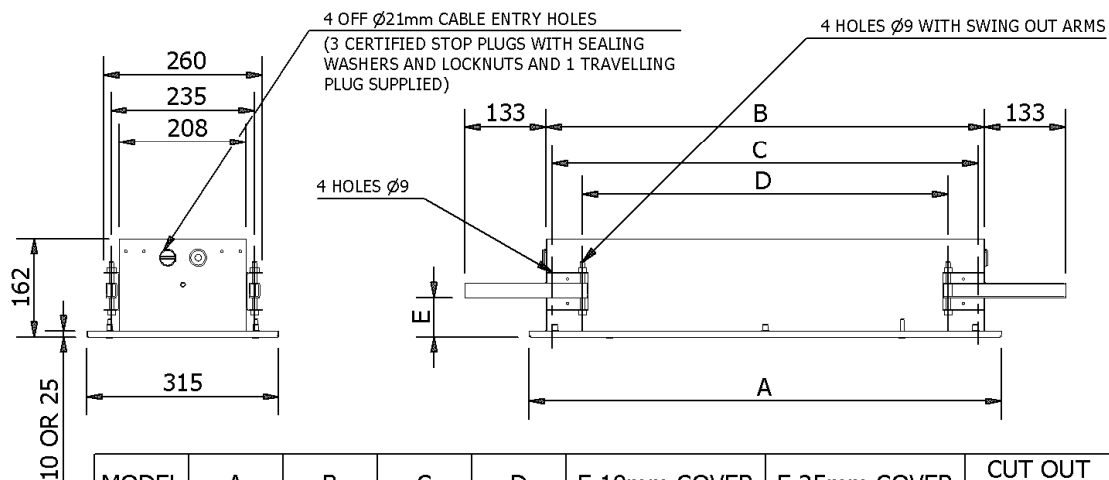

MODEL	A	B	C	D	E 10mm COVER	E 25mm COVER	CUT OUT SIZES
2X18W	775	720	700	600	35 TO 70	20 TO 55	300 X 740
2X36W	1390	1335	1315	1215	"	"	300 X 1355



0.0 Specification	
Type Of Protection	Ex eb mb op is q Increased safety, Encapsulation, optical radiation, powder filling. (With isolating switch: Ex db eb mb op is q Flameproof is added)
Protection Standards	(IEC) EN 60079-0, (IEC) EN 60079-1, (IEC) EN 60079-5, (IEC) EN 60079-7, (IEC) EN 60079-18, (IEC) EN 60079-28, (IEC) EN 61241-1
Area Classification	Zone 1 and Zone 2 areas to (IEC) EN 60079-10-1 Zone 21 and Zone 22 areas to (IEC) EN 60079-10-2
Installation	(IEC) EN 60079-14
Certificate	IEC certificate of conformity IECEx CML 16.0043X EC type examination certificate CML 16ATEX3095X
Equipment Coding	Ex eb mb op is q IIC T4 Gb or Ex db eb mb op is q IIC T4 Gb Ex tb IIIC T95°C Db IP6X (-40 to +45°C Insulated, +55°C Uninsulated)
ATEX Coding	II 2GD
Ingress Protection	IP65 to EN 60529
CE Mark 	The CE marking of this product applies to "The Electrical Equipment (Safety) Regulations 2006", "The Electromagnetic Compatibility Regulations 2004", the "Waste Electrical and Electronic Equipment Regulations 2006" and the "Equipment and Protective Systems intended for use in Explosive Atmospheres Regulations 1996". [This legislation is the equivalent in UK law of EU directives 2014/35/EU, 2014/30/EU, 2012/19/EU and 2014/34/EU respectively]. The Equipment is declared to meet the provisions of the ATEX directive (2014/34/EU) by reason of the EC Type Examination and compliance with the Essential Health and Safety Requirements. M Poutney Technical Manager

SPECIAL CONDITIONS FOR SAFE USE

- Connections to the terminals must not be made outside the range of -10°C to +80°C.
- Where used, all terminal screws, used and unused, shall be tightened down to between 1.2 Nm and 2Nm.

1.0 Introduction – Acclaim LED Model

This installation leaflet covers the range of ATEX and IECEx Acclaim recessed luminaire models with the Ex mb LED strips and the Ex q control gear. These luminaires are mainly used in harsh environments and are constructed using a painted steel body and polycarbonate diffuser. Refer to the current catalogue for information on product references. The luminaires are available in 02L (2ft) and 04L (4ft) sizes.

B15 SOLAS The luminaire can be installed to interface with fire resistant ceiling systems to maintain a B15 SOLAS fire rating; the integrity of the ceiling and insulation must be maintained using suitable insulation materials. The ceiling/fitting and insulation should be continuous (without any gaps), care must be taken to maintain this classification.

1.1 Electrical Supplies

Lamps	02L – 2 x 600mm LED Strip	04L – 2 x 1200mm LED Strip
Voltage range AC	110-130V or 220-254V	
Frequency range Hz	47-63Hz	
Power Watts 220-254V	30W	60W
Current Amps 220-254V	0.16A	0.30A
Power Watts 110-130V	30W	60W
Current Amps 110-130V	0.28A	0.55A

The safety limit for surface temperature (T rating) is +/-10% on the rated voltage. Equipment should not be operated continuously at more than +10/-10% of the rated voltage of the control gear.

Power Factor >0.95	Power is constant over voltage range.
Over voltage	400V ac for 1 min and EN 61000-4-5 > 4kV
Through Wiring	The through current rating is 16A. 4mm ² terminals are standard (6mm ² wiring can be used in the terminals in accordance with the luminaire certificate).
Tamb Storage	-40°C to +80°C
Storage	Luminaires are to be stored in cool dry conditions preventing ingress of moisture and condensation.
Fuse and MCB Ratings	It is recommended that for selection of MCBs users should consult the MCB manufacturer as this unit contains electronic control gear. MCB ratings can vary depending on the manufacturer and type and the size of the installation. The electronic control gear has nominal values of inrush current of 35A for 70µs on 230V and 70A for 70µs on 110V.

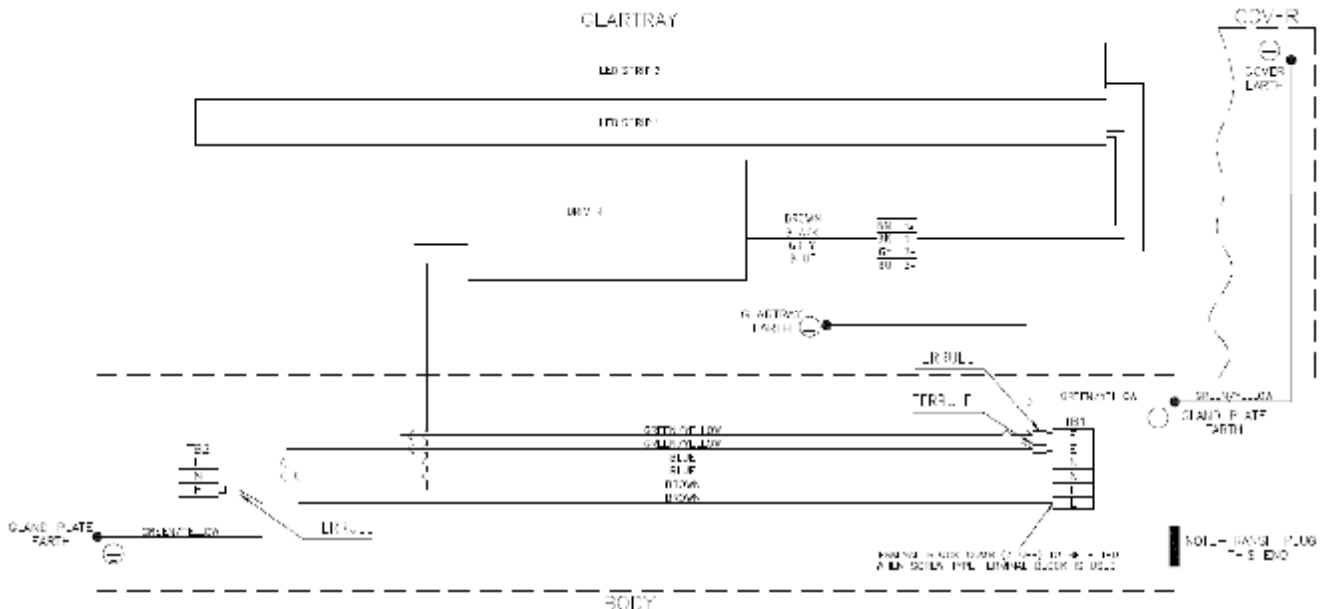

2.0 Installation and Safety

2.1 General

These instructions should be read fully and carefully before attempting to install the luminaire. For details of servicing operations, opening etc. see section 3.0.

Note: This range is available in a number of similar but distinctly different versions. Care must be taken to use the correct instructions and spares, if in doubt contact sales or product support.

Copies of these instructions should be held in a safe place for future reference. It is the responsibility of the installer to ensure that the apparatus selected is fit for its intended purpose and that the installation, operation and maintenance of the apparatus complies with applicable regulations, standards or codes of practice. Installation should be carried out in accordance with (IEC) EN 60079-14 or with a local hazardous area code of practice, whichever is appropriate.

Risk of electrostatic discharge:

- Clean diffuser only with damp cloth
- Avoid mounting near fast moving streams of air

Any specific installation instructions must be referred to. In the UK the requirements of the *Health and Safety at Work Act* must be met and electrical work associated with this product must be in accordance with the *"Manual Handling Operations Regulations"* and *"Electricity at Works Regulations 1989"*. Disposal instructions should be complied with. The luminaires should be considered Class 1 to EN 60598 and effectively earthed. Certification details on the rating plate must be verified

against the application requirements before installation. The information in this leaflet is correct at the time of publication. The company reserves the right to make specification changes as required without notice.

2.1.1 Use in Combustible Dust Atmospheres

Where the equipment is used in combustible dust atmospheres reference must be made to the selection and installation standards in order that the equipment is used correctly. In particular this applies to the de-rating of surface temperature for use where dust clouds may be present. Dust layers should not be allowed to accumulate on the fitting surface and good housekeeping is required for safe operation. Dust in layers has the potential to form ignitable clouds and to burn at lower temperatures.

Refer to EN 60079-10-2 and EN60079-14 for additional details of selection, installation and maintenance.

2.2 Tools

12mm, 3mm and 4mm flat blade screwdriver and large crosshead screwdriver. Allen Key for adjusting swing out arms. Suitable spanners for installing cable glands. Pliers, knife, wire strippers/cutters.

2.4 Mounting

Luminaires should be installed where access for maintenance is practical and in accordance with lighting design information. Refer to the note in 2.1 concerning electrostatic charge.

When mounting of ceiling support channels, via side arms or adjustable side arms, they must be secured onto channels by fixing screws. When B15 fire rating is a requirement all conditions stated by the ceiling manufacturer and Chalmit must be met.

As an insulated recessed unit the Tamb rating is 45°C as a non-insulated unit in a plain recess the Tamb rating is 55°C. Therefore the usual mounting in a metal ceiling with 75 mm of insulation at 45°C is acceptable. If the temperature in an installation is continuously at the limiting level the duration will be reduced and the self-testing will be delayed.

2.5 Cabling and Cable Glands

The temperature conditions at the supply cable entry point are such that 70°C (ordinary PVC) cable can be used. Cable glands and sealing plugs must have ATEX component approval. The cable and gland assembly when installed must maintain a minimum IP54 rating.

Four entries are provided. Three entries are fitted with suitably approved blanking plugs, the fourth entry with a transit plug. M20 x 1.5 entries are standard, other sizes are available on request.

2.6 Electrical Connections and Testing

If any work is to be done on any luminaire already connected to the electrical system, the luminaire must be isolated from the system.

Access for the cabling is via removal of front cover and lamp tray. The front cover is secured using 6/10 off M6 captive screws; care to be taken as there is no suspension with this only the earth connection. The lampholder tray is secured by M5 screws and keyhole slots, with chain suspension allowing the tray to swing down, giving access to terminal blocks. Luminaires are supplied suitable for looping and through wiring. Screw type or screw-less "cage clamp" terminals are fitted in the range of luminaires. Mains terminal blocks are marked L N Earth.

An earth terminal is fitted to the cover and must be reconnected prior to re-affixing the cover to the body.

The maximum amount of insulation allowed beyond the throat of the terminal is 1mm. The normal method of insulation testing is to connect Live and Neutral together and test between this point and Earth to prevent the risk of damage to the electronic control gear. However, if this is not possible luminaires can be tested with an insulation tester that complies with IEC 364 or BS 7671 with a maximum output current of 1mA and output voltage of 500V dc. (Units damaged by incorrect insulation testing can be detected).

Before completing the wiring, ensure that all the connections are correctly introduced into place before reassembling the luminaire.

3.0 Servicing and Operation

Safe servicing behind the gear tray requires the mains supply to be isolated.

3.1 Opening and Closing

The front cover is secured using 6/10 off M6 captive screws; care to be taken to avoid damage, the cover will hang down via two nylon straps with clip release at each end attached to the gasket blade and the body chassis.

3.3 Releasing the Reflector/Gear Tray

Loosen the four fixing screws retaining the reflector/gear tray far enough for it to slide over keyhole slots. The tray will hang on the retaining cords without stressing the wiring between body and tray. Replace in reverse order.

3.4 Servicing Behind the Gear Tray

The release of the gear tray exposes live mains terminals. Any work behind the gear tray requires that the supply is isolated to avoid ignition risk and damage to components.

3.5 Replacement of Driver

The driver contains no serviceable parts. Should it be found necessary to replace the driver, the following procedure should be adopted: Ensure that the luminaire is isolated from the mains supply.

Remove gear tray from body and swing down as previously explained. Disconnect the driver wires from the terminal blocks (note the connections) and remove the driver from the tray.

3.6 Replacement of LED Strips

Remove gear tray from the body and swing down as previously explained. Identify the wires for the LED strip/s and disconnect from the terminal block. Remove screws and clips holding the strips in place. Replace strips using screws and clips and reconnect to terminal block. Check connections before re-energising.

4.0 Routine Maintenance

Visual tests and checks should be carried out at intervals described by the appropriate regulations, EN 60079-17, and should include the following:

- Check for mechanical damage/corrosion.
- Check connections, fixings, glands and plugs.
- Check for undue accumulations of dust, dirt or moisture.
- Check for unauthorised modifications.

Periodic inspection of the enclosure seal should be carried out to ensure that the seal is sound. If the luminaire has been subject to abnormal conditions, for example, severe mechanical impact or chemical spillage, it must be de-energised until it has been inspected by an authorised and competent person.

4.1 Cleaning

The body of the luminaire may be cleaned with a mild solution of household detergent and water, after cleaning the body should be washed and wiped with clean water. **The diffuser should not be polished or wiped with a dry cloth as a risk of ignition due to electrostatic discharge may result.** Cleaning of the diffuser with any chemical or hydrocarbon solvent based cleaner may result in severe damage.

5.0 Disposal of Material

Disposal of the luminaire as waste should be carried out in accordance with national regulations. Any disposal must satisfy the requirements of the WEEE directive [2012/19/EU] and therefore must not be treated as commercial waste. The unit is mainly made from incombustible materials. The control gear contains plastic, resin and electronic components. All electrical components may give off noxious fumes if incinerated.





To comply with the Waste Electrical and Electronic Equipment directive 2012/19/EU the apparatus cannot be classified as commercial waste and as such must be disposed of or recycled in such a manner as to reduce the environmental impact.

Chalmit Lighting is a leading supplier of Hazardous Area lighting products

	<p>CHALMIT LIGHTING PO Box 5575 Glasgow, G52 9AP Scotland</p>	
<p>Telephone: +44 (0) 141 882 5555 Fax: +44 (0) 141 883 3704 Email: info@chalmit.com Web: www.chalmit.com</p>	<p>Registered No: 669157 Registered Office: Cannon Place 78 Cannon Street London EC4N 6AF UK</p>	

For technical support, please contact: techsupport@chalmit.com

Note: Chalmit Lighting reserves the right to amend characteristics of our products and all data is for guidance only.

	EU-Declaration of conformity		
	UE-Déclaration de conformité		
	EU-Konformitätserklärung		
Manufacturer	Chalmit	Address	388 Hillington Road, Glasgow. G52 4BL Scotland UK
Product	Acclaim III Recessed Luminaires.		
EC - Type Examination Certificate	Baseefa04ATEX0286		
Notified Body	Baseefa 1180		
ATEX Coding	 II 2GD	ATEX Classification	Group II Category 2 GD
Equipment Coding	Ex eqm II T4 T95°C		
Ingress Protection	IP65		
The technical basis, with respect to equivalence of			
La base technique, en ce qui concerne l'équivalence de			
Die technische Grundlage hinsichtlich der Normen			
Protection Standards EN 50014, EN 50017, EN50019, EN50028, EN 50281-1-1			
Area Classification EN 60079-10-1, EN 60079-10-2.			
of compliance with the EHSRs is valid as there are no changes which materially affect the state of technological progress of the product.			
en conformité avec les EESS est valide puisqu'il n'y a aucun changement qui affecte matériellement l'état de l'évolution technologique du produit.			
zur Erfüllung der GSGA ist gegeben, da keine Änderungen erfolgt sind, die einen Einfluss auf den technischen Stand des Produkts haben.			
Terms of the directive:		Standard & Date Certified to	Standards Date Declared to
Prescription de la directive:		Standard & date certifiée à	Normes date Déclaré
Bestimmungen der Richtlinie:		Standard & Datum Zertifiziert nach	Standards Datum erklärt
2014/34/EU	Equipment and protective systems intended for use in potentially explosive atmospheres.	EN 50014: 1997 Amd 1&2 EN 50017: 1998	
2014/34/UE	Appareils et les systèmes de protection destinés à être utilisés en atmosphères potentiellement explosibles.	EN 50019: 2000	
2014/34/EU	Geräte und Schutzsysteme zur bestimmungsgemäßen Verwendung in explosionsfähigen Bereichen.	EN 50028:1987 EN 50281-1-1: 1998	
2014/30/EU	Electromagnetic compatibility	EN 55015 : 2013	
2014/30/UE	Compatibilité électromagnétique	EN 61547 : 2009	
2014/30/EU	Elektromagnetische Verträglichkeit	EN 61000-3-2 : 2014	
2014/35/EU	Low voltage equipment	EN 60598-1 : 2015	
2014/35/UE	Équipements électriques à bas voltage	EN 60529 : 1992	
2014/35/EU	Niederspannungsgeräte / -systeme	EN 60598-2-2 : 2015	
2012/19/EU	Waste of electrical and electronic equipment		
2012/19/UE	Déchets d'équipements électriques et électroniques		
2012/19/EU	Entsorgung der elektrischen und elektronischen Geräte / Systeme		
2011/65/EU	RoHS II Directive		



On behalf of the Chalmit, I declare that, on the date the equipment accompanied by this declaration is placed on the market, the equipment conforms to all technical and regulatory requirements of the above listed directives.

En tant que représentant du fabricant Chalmit, je déclare qu'à la date où les équipements accompagnant cette déclaration sont mis sur le marché, ceux-ci sont conformes à toutes les dispositions réglementaires et techniques des directives énumérées ci-dessus.

Hiermit bestätige ich, im Namen von Chalmit, dass am Tag der Lieferung des Produkts/der Produkte zusammen mit dieser Erklärung das Gerät/die Geräte alle technischen und regulativen Anforderungen der oben aufgeführten Direktiven erfüllt.

Name and Date Mark Poutney 20/04/2016
Nom et Date
Name und Datum

Technical Manager
Directeur technique
Technischer Leiter

Quality Assurance Notification by:
Notification d'assurance qualité par:
Qualitätssicherungsnotifikation durch:

Baseefa Ltd.
1180

Quality Management System Accreditation:
Système de Management Qualité Accréditation:
Qualitätsmanagementsystem Akkreditierung:
Environmental Management System.
Système de gestion de l'environnement.
Umwelt kontroll system.
Certificate No./Certificat N°/Zertifikat Nr.

ISO 9001

ISO 14001
by/par/durch
Lloyd's Register
LRQ 4005876